



Jinan Ruby Laser Technology Co.,Ltd

Add: C-501 Room,C Unit,Kaibeite Building,Huaxin Road,Licheng District,Jinan,
Shandong Province,China.250199.

Tel: 086-531-58181378 E-mail: sales@rubylasercutting.com

MYKZ40W,MYJG40W,MYJG60W ,MYJ G80W and MYJG130W CO2 Power Supply



Features :

MYKZ40W,MYJG40W,MYJG60W,MYJG80W or MYJG130W series high frequency CO2 laser power supplies are co-developed by authoritative CO2 laser tube manufacturer and our company. It is high efficient, high frequency and high speed CO2 laser power supply which has small size,light weight,easy operation, excellent match with CO2 tube and other features. It reduce heavy and feverish ballast and can be directly connected with CO2 laser tube. This power supply makes CO2 laser tube ignite easy,fully play its performance, realize high conversion rate and prolong CO2 tube's life time.

Specification :

1. Input voltage:AC110/220V(Specify before place order)
2. Output laser ignition voltage: DC 40KV(130W),DC 35KV(W) DC 30(KV) DC 26KV(40W)
3. Max output current: DC 38mA(130W),DC 30mA(80W) DC 24mA(60W) DC 20mA(40W).
4. Response speed: $\leq 1\text{mS}$.
5. TTL level control: Effective high level or low level is optional
6. Protect switch: It can detect water and protect CO2 tube or offer protection when open power supply's outside case.
7. Laser power control: (1)Potentiometer adjust output current.(2) PWM(amplitude is TTL level)
8. It is used to test CO2 laser tube's actual working current.
9. Working environment: Temperature(-10~40) $^{\circ}\text{C}$,Humidity: $\leq 85\%$.

10. Size : (1) KZ40W: 165*145*90 (mm)
 (2) JG40W: 180*144*91(mm)
 (3)60W: 207*144*91(mm);
 (4)80W: 280*173*97(mm)
 (5)130W: 350*243*97(mm)

Instructions :

1)Wiring connection with CO2 laser tube :

CO2 power supply's high voltage terminal(HV+)must be connected with CO2 tube's positive pole terminal(Total reflection end). CO2 power supply's current circuit should be connected with CO2 tube's negative pole through ammeter or directly be connected with CO2 tube's negative pole.

2)Wiring connection with control signal:

Fig1(or Fig2),Control signal wires should be respectively connected with CO2 power supply's control terminal.

3)Control signal input:

As Fig 3 shows, external computer's output DAC signal and TTL signal are input to CO2 power supply as required. After that, it can control CO2 tube's output laser.

4)Voltage :

220VAC/50Hz is default input voltage. If 110VAC,please specify before place order.

5)Additional functions:

CO2 power supply has a protect interface which can be connected with water protection switch in series. It can offer protection when open power supply's outside case.

Notice :

1. When CO2 tube works, water must be used for cooling.
2. High voltage output terminal forbids having open circuit(High voltage's positive and negative terminals must be correctly connected with CO2 tube's corresponding terminals).
3. CO2 power supply has leak resistance. After power off, it will leaks residual voltage in 1-2 seconds. For security, please also pay attention to electric shock. (High voltage two terminals must be hanged and meet 40KV high voltage insulation's requirement)
- 4.CO2 power supply must use three hole socket with earthing end. Outside case must is connected with earth strictly.

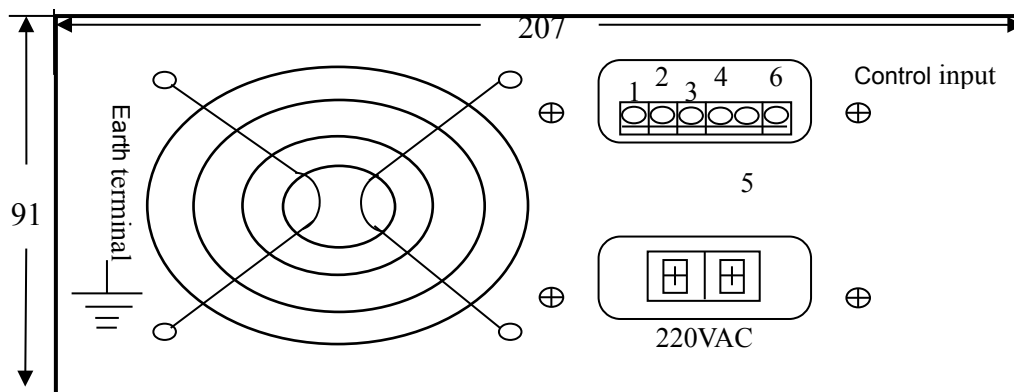

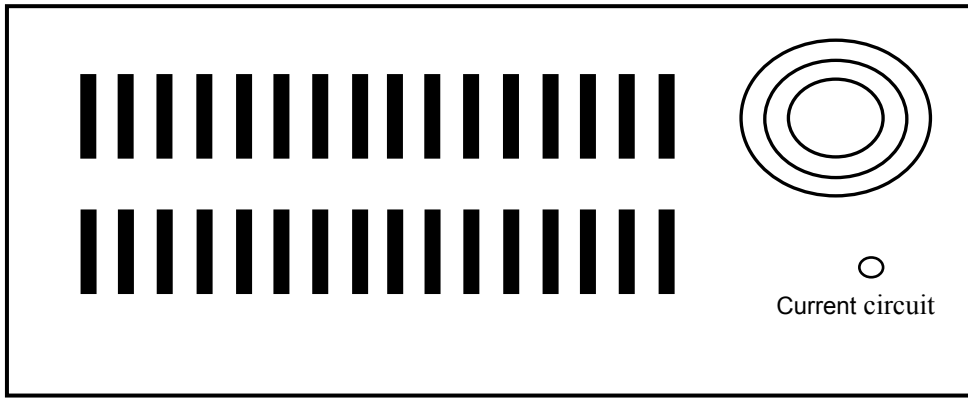

Fig 1 60W CO2 power supply

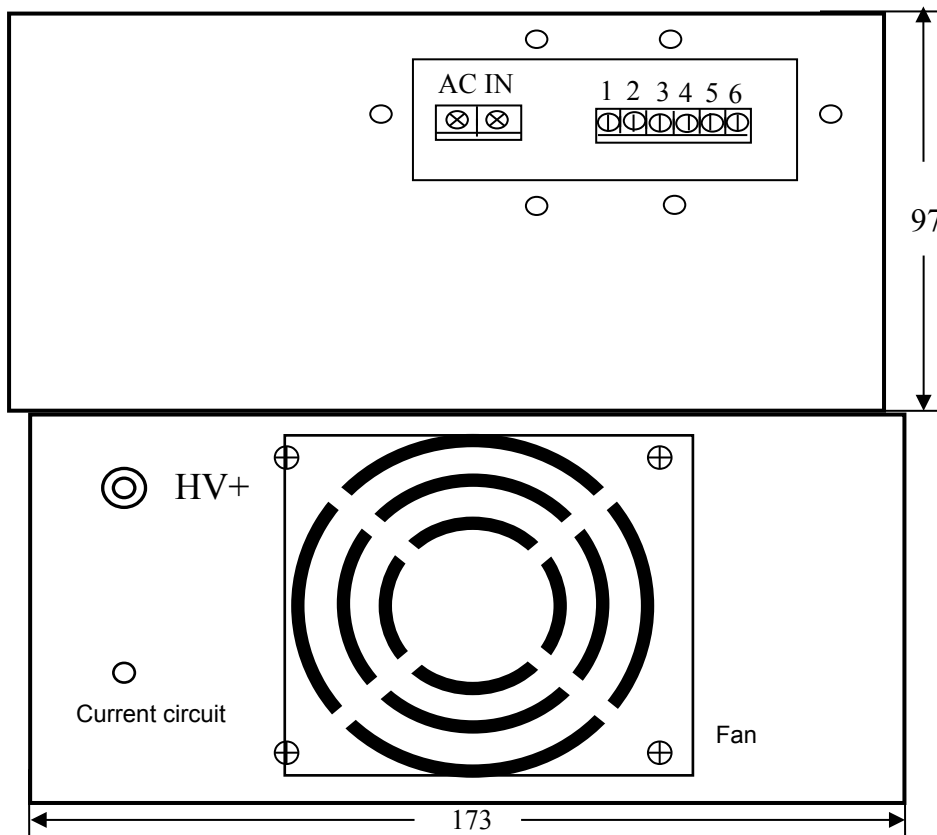
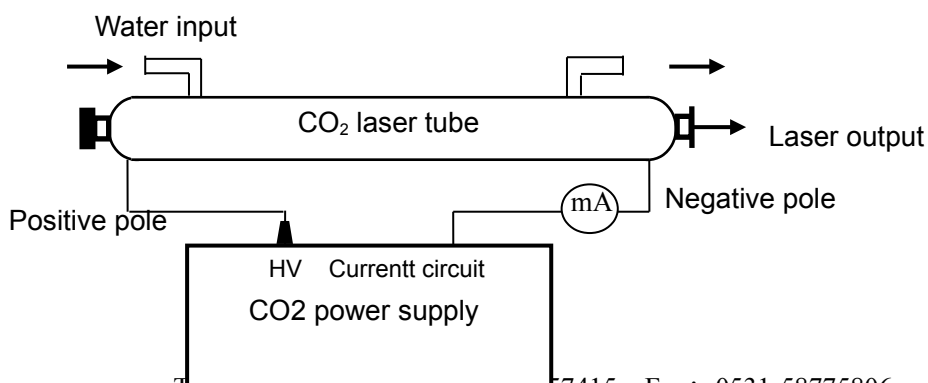
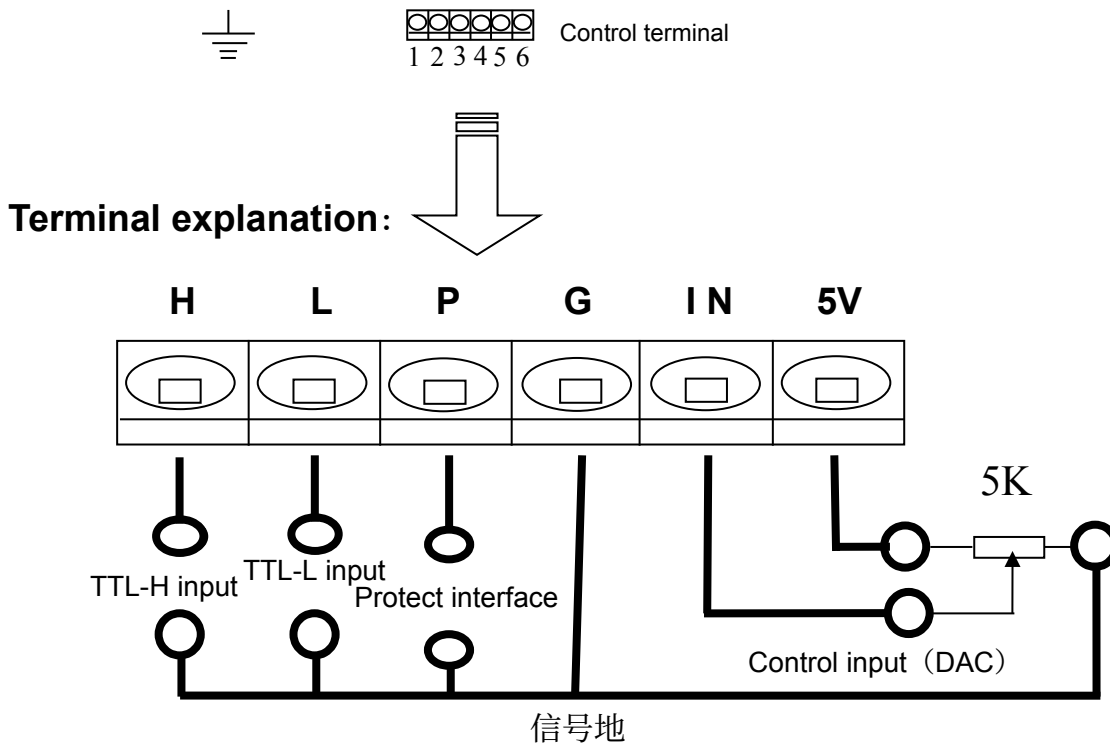

Fig 2 80W CO2 power supply

Connection wiring diagram of power supply and CO2 tube :





Control terminal function:

TTL-H input	TTL-L input	Control input(DAC)	Laser output
hanged	low(<0.3V)	0-5V	Pmin - Pmax
	high(>3V)	0-5V	0
low(<0.3V)	hanged	0-5V	0
high(>3V)		0-5V	Pmin - Pmax
Protect interface open		0-5V	0

Fig 3

Connection wiring diagram of power supply and CO2 tube:

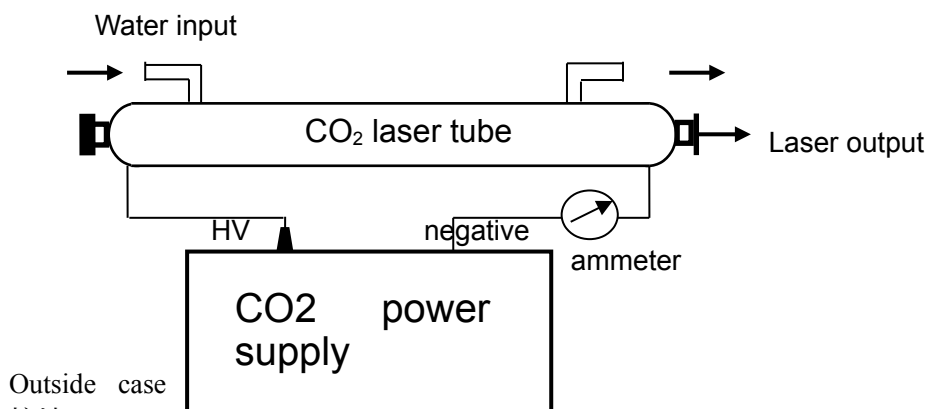



Terminal explanation:

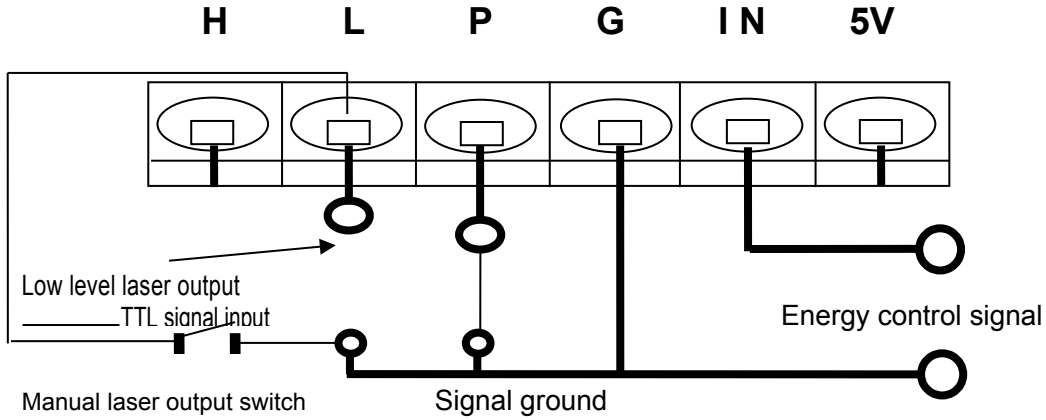
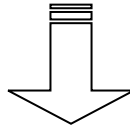

Note: it has two methods for energy control signal

A: (RF laser)pulser: PWM.

B: 0-5V analog signal

Fig 4 When low level for laser output, TTL signal wiring connection diagram

Connection wiring diagram of power supply and CO2 tube:

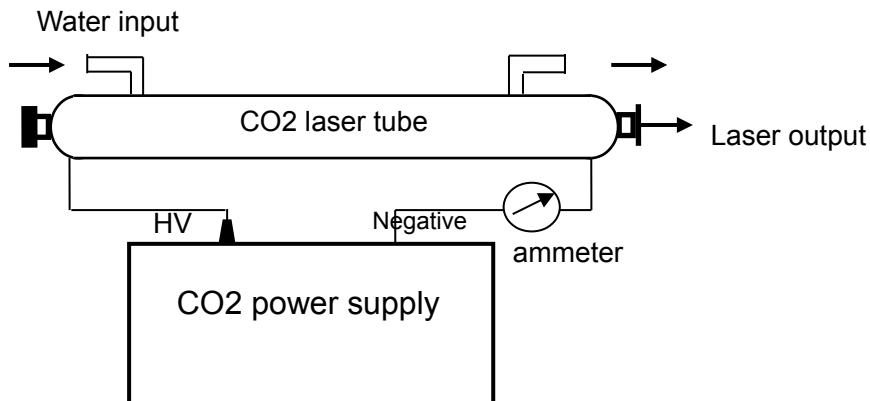

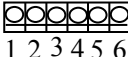
Outside case connected with earth   Control signal
1 2 3 4 5 6

Terminal explanation:

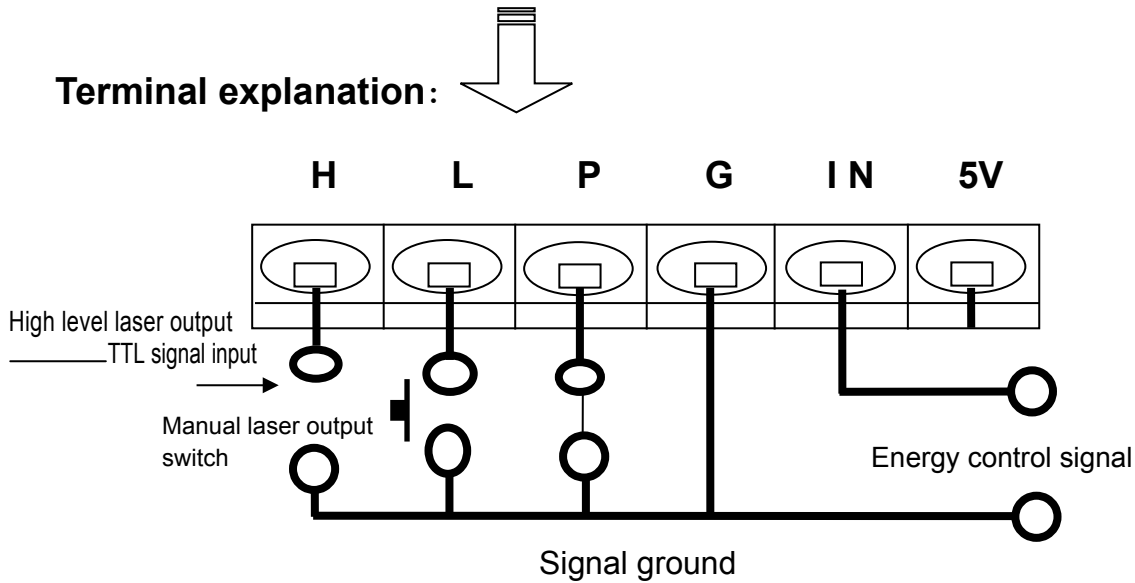

Note: it has two methods for energy control signal

A: (RF laser)pulser: PWM

B: 0-5V analog signal

Fig 5 When high level for laser output, TTL signal wiring connection diagram

Attachment 1: CO2 power supply specification

Model	Rated power(W)	Ignition voltage (KV)	Working voltage (KV)	Working current (mA)
40W power supply	300	26	11	4--20
60W power supply	400	30	16	6--24
80W power supply	500	35	18	7--30
130W power supply	650	40	32	8--38

Attachment 2 Indicator instruction:

POWER: Power on indicator(green lamp)

LASER: High voltage output indicator(red lamp)

TEST: Power supply failure test switch

When power on, power lamp blinks, power supply is in standby status.

After get high voltage signal,laser lamp blinks,power supply works normally.

Power supply failure explanation :

When power supply is standby status,press TEST switch, Laser lamp blinks,CO2 laser tube output laser. If lamp deosn't blink, it means power supply is damaged. If lamp blinks and CO2 tube doesn't output laser, it means CO2 tube is damaged.