

www.3wcad.com Before using this product, we recommend that you

Read the hardware manual of the product carefully!

more
small
,
more
Strong
,
more
stable
set
,
more
can
by
,
more
:

M2NanoDRV

the Lord
board Lee
hard Bright
Pieces Yu
hand
book

Lihuiyu Studio Labs.

M2NanoDRV It is a control board that can be connected to a stepper motor driver.

M2Nano The motherboard integrates a small current X axis,Y Shaft stepper motor drive, the drive torque that can be provided is limited, therefore, it cannot Drive a heavier plotter. To this end, we have designed a base in **M2Nano** Kernel **M2NanoDRV** Control board, can be connected with steps Into the motor driver, which can be based on the torque required by the plotter Size, choose a suitable drive.

Note: **M2NanoDRV** Optional suitable driver, can drive 42 Stepper motor,57 Stepper motors and more!

2016 year 11 month 17 day

Writer: Li Huiyu



Chapter One: M2NanoDRV Introduction to Main Board

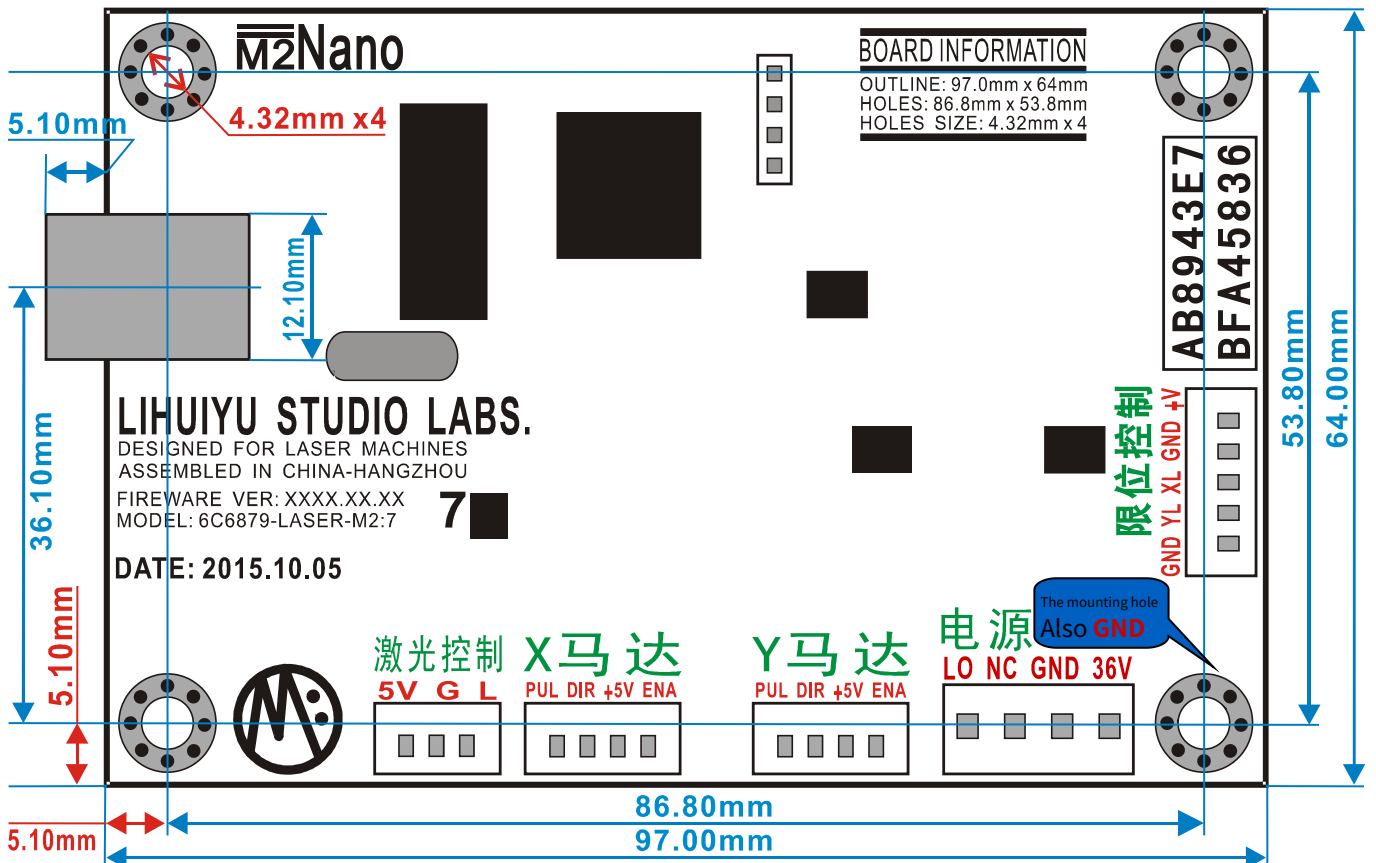
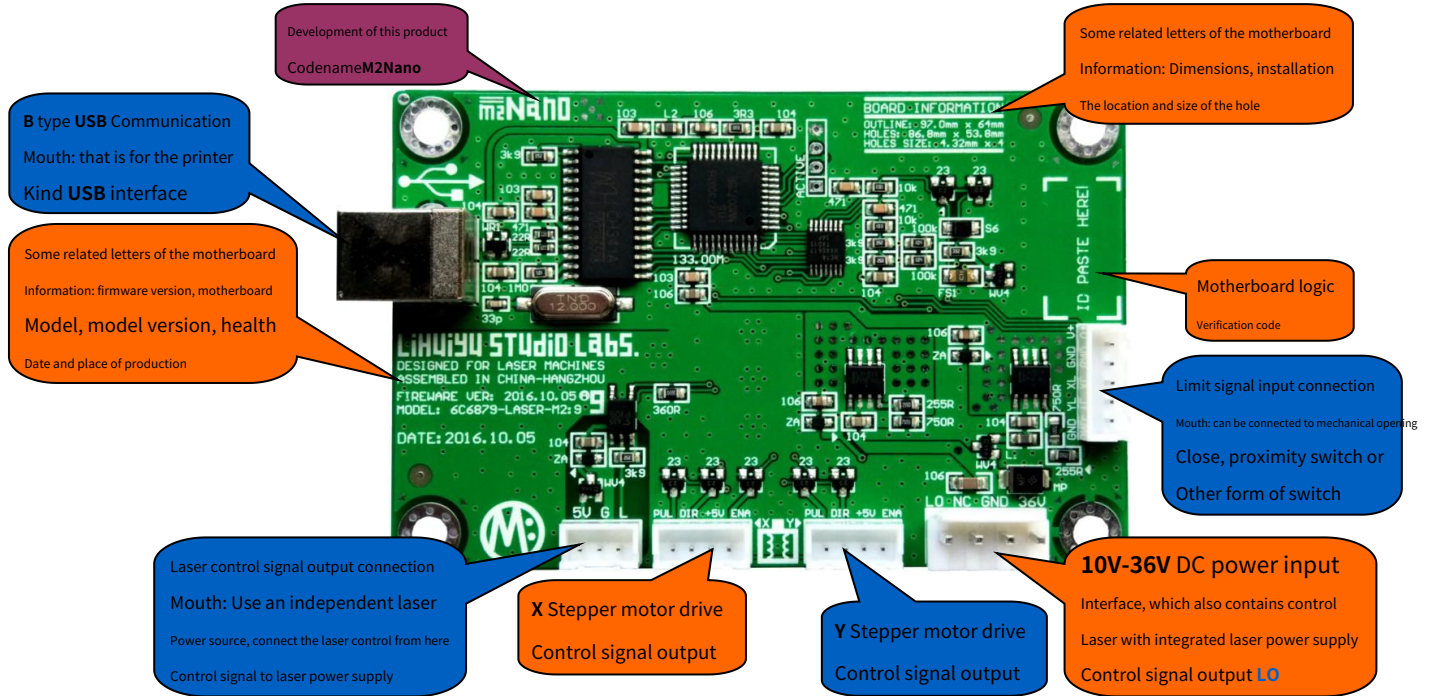

wiring

power supply: **LO NC GND 36V**

36V: Indicates that the maximum power supply voltage cannot exceed 36V, It's not necessary to use

36V Power supply, recommended 10V-36V; Please note: the power supply voltage exceeds 36V

Will result in M2NanoDRV The control board is damaged!

GND: Power ground;

NC: Not used, that is, no wiring is required;

LO: Laser control signal output, low level turns on the laser, high level turns off the laser;

M2NanoDRV The connection line with the integrated laser power supply is made as shown below:



Note: If you are using an independent laser power supply, you only need to connect two power cords

36V(10V-36V),GND Yes,**NC,LO** No wiring is required.

X motor,Y motor:PUL DIR +5V ENA

PUL: Step pulse output;

DIR: Direction signal output;

+5V:5V Power output (maximum output 0.05A = 50mA);

ENA: Offline control signal (offline, that is, the stepper motor is in a free state);

(1),M2NanoDRV Wiring method of stepper motor driver with single-ended control signal:

PUL:Driven PUL;

DIR:Driven DIR;

+5V:Driven VCC or OPTO(For example, Lei Sai drive);

ENA:Driven ENA.

(2),M2NanoDRV Wiring method of stepping motor driver with differential control signal:

PUL:Driven PUL-;

DIR:Driven DIR-;

+5V:Driven PUL +,DIR +,ENA +;

ENA: Connected to the drive ENA-.

Laser control:5V GL

If you use an integrated laser power supply, then the socket does not need to be wired, if you use an

independent laser power supply, then connect according to the following scheme:

5V: Connect to independent laser power supply 5V;

G: Connect to independent laser power supply G;

L: Connect to independent laser power supply L(or TL)

Limit switch:GND YL XL GND V+

GND:Signal ground

YL: Y Axis limit signal input;

XL: X Axis limit signal input;

GNDSignal ground

V+: Power supply (when using electronic limit, a power supply is needed)

Description:V+That is the power input from the control board, that is, the power socket (LO NC

GND 36V)of 36V The voltage of the pin input.

(1)、The wiring method of mechanical switch as limit switch:

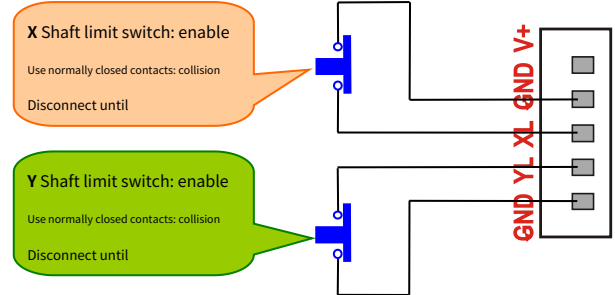

The advantage of mechanical limit switch is that the wiring is simple, and it is not easy to be

From electrical damage. However, it is recommended to use high-quality limit switches, because inferior limit switches not only have a limited lifespan, but also the large contact vibration may lead to unsatisfactory positioning accuracy.

(2),The wiring method of proximity switch as limit switch:

Proximity switch is a non-contact sensor, it

A specific material (such as metal) determines its output state. How to choose a suitable proximity switch as a limit switch?

A, The working voltage of the proximity switch must be the same as M2NanoDRVPower supply

Pressure matching, such as M2NanoDRV The power supply is 36V,

Then you have to choose 36V Working proximity switch;

B, The detection distance of the proximity switch. The detection distance of the proximity switch is not

Should be too large, it is generally recommended to select a detection distance of 5mm - 8mm

Proximity switch;

C, The working frequency and hysteresis of the proximity switch. Working frequency

High, the smaller the return difference, the more precise positioning accuracy can be obtained;

D, Should use three-wire NPN Normally closed Proximity switch. Three lines

NPN Proximity switch is an open-collector output structure. If

You don't know what is called open collector output structure, please put

Send the following picture to the proximity switch supplier:

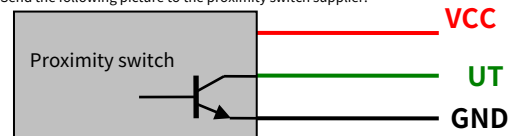

E2. Proximity switches with strong anti-interference ability should be selected. Anti-interference ability

Poor proximity switches may cause errors due to electromagnetic interference

Action, thereby affecting the accuracy of positioning.

M2NanoDRV The wiring method with the proximity switch is shown in the figure below:

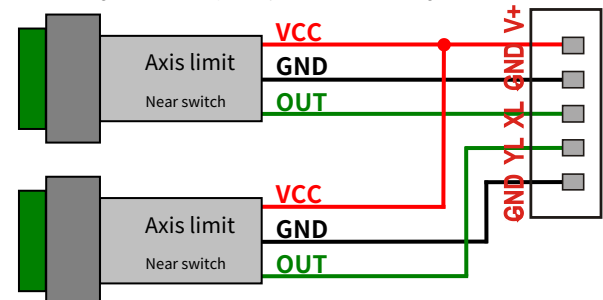

It is generally considered that proximity switches are only suitable for positioning precision as limit switches.

Occasions where the degree of demand is not high.M2NanoDRV The software and hardware coordination method is

adopted to greatly improve the repeat positioning accuracy of the proximity switch.

M2NanoDRV Installation demonstration diagram

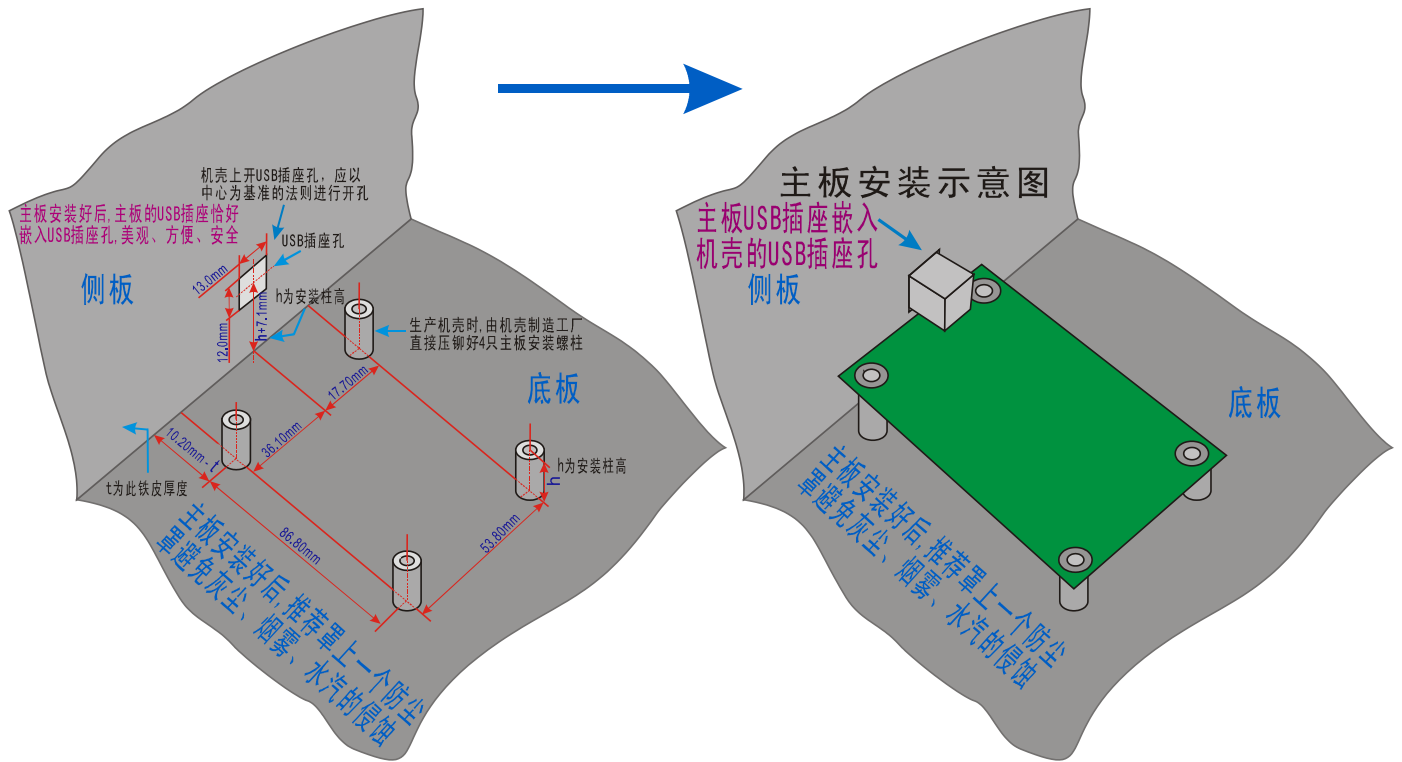

Chapter 2: Motor, Synchronous Wheel, Driver Subdivision, Software Setting

The first option:

0.9° of 42 Stepper motor

20 Tooth MXL Synchronizing wheel

MXL Synchronous belt, the width of the synchronous belt is selected according to the load;

The motor driver subdivision is set to 16 Subdivision (or 3200);

Control panel model selection 6C6879-LASER-M2, Logical resolution Set as 1000dpi, As shown below:



The second option:

1.8° of 42 Stepper motor

20 Tooth MXL Synchronizing wheel

MXL Synchronous belt, the width of the synchronous belt is selected according to the load;

The motor driver subdivision is set to 32 Subdivision (or 6400);

Control panel model selection 6C6879-LASER-M2, Logical resolution Set as 1000dpi, As shown below:



The third option:

0.9° of 57 Stepper motor

40 Tooth MXL Synchronizing wheel

MXL Synchronous belt, the width of the synchronous belt is selected according to the load;

The motor driver subdivision is set to 32 Subdivision (or 6400);

Control panel model selection 6C6879-LASER-M2, Logical resolution Set as 1000dpi, As shown below:



The fourth option

1.8° of 57 Stepper motor

40 Tooth MXL Synchronizing wheel

MXL Synchronous belt, the width of the synchronous belt is selected according to the load;

The motor driver subdivision is set to 64 Subdivision (or 12800);

Control panel model selection 6C6879-LASER-M2, Logical resolution

Set as 1000dpi, As shown below:



The fifth option

0.9° of 57 Stepper motor

twenty four Tooth 3M Synchronizing wheel

3M Synchronous belt, the width of the synchronous belt is selected according to the load;

The motor driver subdivision is set to 32 Subdivision (or 6400);

Control panel model selection 6C6879-LASER-M2, Logical resolution

Set as 1129dpi, As shown below:



Sixth option

1.8° of 57 Stepper motor

twenty four Tooth 3M Synchronizing wheel

3M Synchronous belt, the width of the synchronous belt is selected according to the load;

The motor driver subdivision is set to 64 Subdivision (or 12800);

Control panel model selection 6C6879-LASER-M2, Logical resolution

Set as 1129dpi, As shown below:



Regarding the choice of motor and power supply:

M2NanoDRV Designed to drive a heavier plotter, how do we choose a motor and power supply?

The first scheme and the second scheme use 42 Stepper motor:

XShaft selection 34mm-36mm Thick 1.7A-2.0A of 42 Stepper motor

Shaft selection 44mm-48mm Thick 2.0A-2.4A of 42

Stepper motors; stepper motors are used for derating: driver current setting

It is recommended not to exceed 1.5A.

Choose 24V/6A Switching power supply: approximately 150W of 24V Open

Turn off the power. If you need better high-speed performance, you can also choose

36V/6A The switching power supply about 200W of 36V Switching power supply.

The third, fourth, fifth, and sixth schemes are used 57 Stepper motor:

XShaft selection 40mm-60mm Thick 2.5A-3.5A of 57 Stepper motor

Shaft selection 50mm-80mm Thick 3.0A-3.5A of 57

Stepper motors; stepper motors are used for derating: driver current setting

It is recommended not to exceed 2.5A.

Choose 36V/8A Switching power supply: approximately 300W of 36V Open

Turn off the power.

Why do we recommend derating the use of stepper motors? Because of step

If the motor is used at full load, not only will the noise and heat be large, but And the motion accuracy may be affected. How to set the drive current to the

best value? Some people think that the drive current of a stepper motor is Larger, the higher the speed of the stepper motor, the greater the torque. This way of saying

The law is one-sided, and we won't dwell on the specific reasons here. We only talk about

How to set the current of the driver to the best value. If a laser

When the current of the driver is set to a certain gear, it can just guarantee

If the laser machine is in a good position at the highest speed (set to a lower current,

it will be dislocated), then set the current to a higher gear. Another method is: When

the driver current is set to be larger, the operating speed of the laser machine no

longer increases or the increase is limited, then we do not

Increase the drive current!

third chapter:M2NanoDRV System composition

One by M2NanoDRV As the control core of the laser engraving machine, it should be composed of these modules:M2NanoDRV Control board, laser power supply,X Axis stepper motor driver,Y Axis stepper motor driver, power supply (M2NanoDRV The power supply of the control board,X Power supply for shaft stepper motor driver,Y The power supply of the shaft stepper motor driver).

Fully isolated system configuration

The so-called fully isolated system means that the various modules that constitute the system have no electrical direct connection. Therefore, in theory, there is no electrical mutual interference, thereby improving the reliability of the system. The fully isolated system is the most reliable (the strongest anti-interference ability), but the fully isolated system requires each module Independent power supply, so the cost is relatively high. As shown in the figure below, a fully isolated system requires3 An independent power supply.

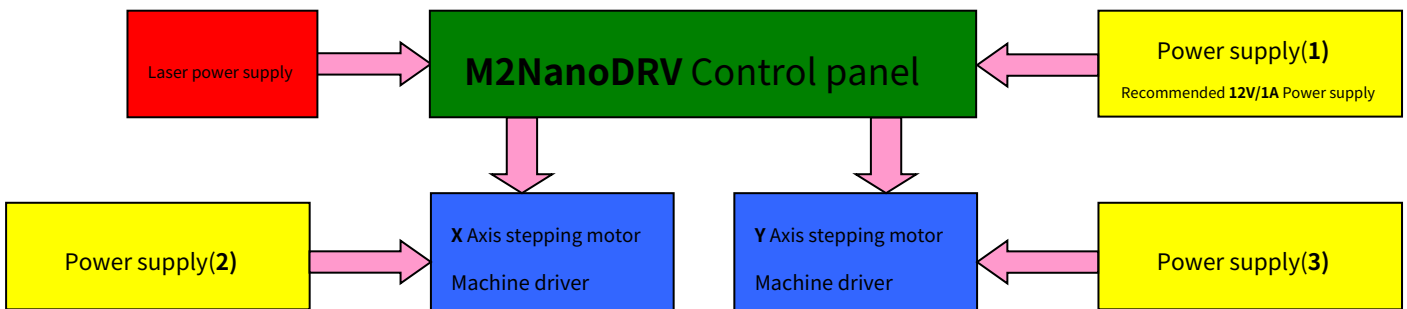

Semi-isolated system configuration (recommend)

M2NanoDRV The control board uses one power supply, and the two stepper motor drivers share one power supply.

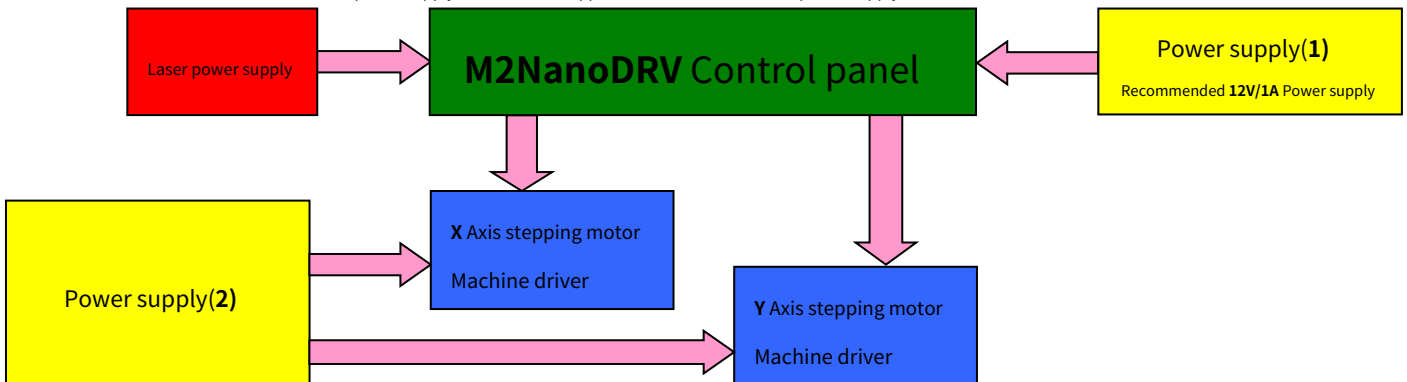

Non-isolated system configuration

M2NanoDRV The control board and the two stepper motor drivers share the same power supply. The non-isolated system has the lowest cost, but also the worst reliability, because the large current chopping action of the stepper motor driver will cause strong interference, which may causeUSB Communication is abnormal.

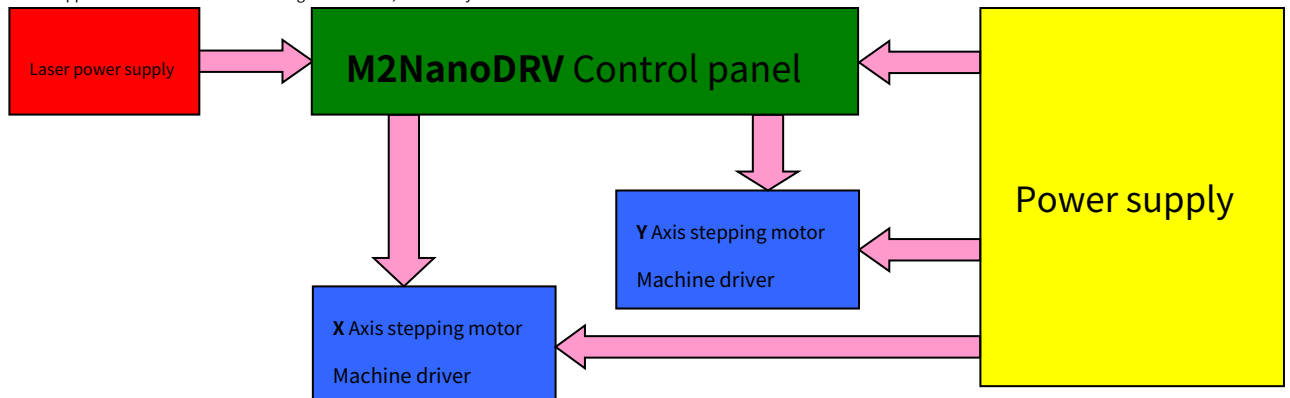

Appendix: Step by step provision of stepper motor driver supply

Currently, the drives available in our office are **M415DRV**(The maximum peak current is **1.60A**, But it is recommended not to exceed **1.50A**),As shown below. For detailed technical information about the drive, please refer to "**M415DRV Stepper motor driver manual** , We only describe the performance of our test here.



Test one (Control panel:M2NanoDRV, The logical resolution is 1000dpi, Which is the second option mentioned in Chapter 2)

track:X axis,Y Axes are **12mm**Wide square linear guide (X track **600mm**,Y track **400mm**), There is no deceleration structure designed on the machine;

Motor:X The motor is **1.8°**,**34mm** thick,**1.70A** of **42** Stepper motor,Y Axis is **1.8°**,**48mm** Thick **2.20A** of **42** Stepper motors; two **42**

The motors are all customized by us, and the two bearings in the motor are **NMB** (Minebea) high-speed bearings;

Synchronous wheels and belts:**20** Tooth **MXL** Synchronous wheel,**10mm**Wide **MXL** Timing belt

Driver subdivision and current setting: both stepper motor drivers are set to **32** Subdivision,**1.40A**;

Switching power supply:**150W**of **24V** The switching power supply supplies power to the two stepper motor drivers,**12V** of **10W**Small switching power supply **M2NanoDRV** powered by;

Test result: The highest engraving speed that can run stably is **800mm/s**,Motor speed is about **1180RPM**;

Test two (Control panel:M2NanoDRV, The logical resolution is 1000dpi, Which is the third option mentioned in Chapter 2)

track:X axis,Y Axes are **15mm**Wide square linear guide (X track **750mm**,Y track **550mm**), There is no deceleration structure designed on the machine;

Motor:X The motor is **0.9°**,**45mm**thick,**2.50A** of **57** Stepper motor,Y Axis is **0.9°**,**56mm** Thick **3.0A** of **57** Stepper motors; two **57**

The motors are all customized by us, and the two bearings in the motor are **NMB** (Minebea) high-speed bearings;

Synchronous wheels and belts:**40** Tooth **MXL** Synchronous wheel,**15mm**Wide **MXL** Timing belt

Driver subdivision and current setting: both stepper motor drivers are set to **32** Subdivision,**1.50A**;

Switching power supply:**250W**of **36V** The switching power supply supplies power to the two stepper motor drivers,**12V** of **10W**Small switching power supply **M2NanoDRV** powered by;

Test result: The highest engraving speed that can run stably is **800mm/s**,Motor speed is about **590RPM**;

It can be seen from the above two tests:X The shaft motor should choose a motor with a smaller thickness, because a motor with a smaller thickness has a smaller dead weight and a lighter coil inside the motor, so it has excellent acceleration and deceleration characteristics and is more suitable for X High-speed scanning movement back and forth during axis engraving. andY Because the shaft has a heavier load, a thicker motor should be selected to ensure sufficient torque output. At the same time, because the speed of the stepping motor is very high during high-speed engraving, high-quality high-speed bearings should be used for the two bearings in the stepping motor to ensure smooth and reliable movement.

in conclusion:M2NanoDRV Cooperate M415DRV The driver is completely suitable for manufacturing medium and high-speed durable laser engraving machines with medium and small format; if you choose a driver with a larger drive capacity,M2NanoDRV It is suitable for manufacturing laser engraving machines of any format, especially suitable for manufacturing some large-format, low-cutting speed plate cutting machines (because of laser power limitation, thick plates generally cannot be cut at high speed).

Drive supply service

Our drive will have a considerable price advantage. The price advantage is not to say that it is shoddy, but because we only design for the laser machine industry. For example, the subdivisions of the drivers used in most laser machines are basically fixed, such as **4000(20 Subdivision), 5000(25 Subdivision), 6400(32**

Subdivision), and some of the drivers purchased by laser machine manufacturers have more than a dozen subdivision settings. Can they be used? Excluding the subdivision parts that are not needed by the laser machine industry, there will naturally be a price advantage;

For our driver, the current adjustment step length will be smaller, so that the stepper motor can get the best working current as much as possible. One disadvantage of using the driver is that the control board cannot dynamically adjust the current of the stepper motor, because most of the current of the driver is set by the DIP switch. After the DIP switch is set to a certain current position, the current of the stepper motor is Fixed, the control panel cannot participate in adjustments. However, most drivers have larger current setting steps, such as **0.5A,**

1A, 1.5A, 2A, 2.5A, 3A, 3.5A, 4A, Each step is **0.5A,** So if **1A** Too small, **1.5A** What should I do if it is too big? There is no way. So we will eliminate too many subdivision settings that are not needed, and refine the current adjustment step length, which will be more suitable for laser machine use.

Our driver will do some protection against high voltage. In the laser machine, the laser power supply is a plague-like thing, it can even be said, **10** Secondary hardware failures are **9** Secondly, it was caused by messing up. Most drive manufacturers generally do not consider this particularity.

For some drives, we will integrate the hot-swappable function, that is, they can be directly unplugged without powering up. For most drives, it is strictly forbidden to plug and unplug the motor cable when power is on, otherwise the drive will be destroyed. However, it is difficult to prevent the hot plugging, so repairs caused by this are not rare;

Nowadays, some of the core chips for stepper motor drivers are very advanced, far beyond the traditional stepper motor drivers: some have low-speed automatic frequency multiplication function, some have the function of automatically adjusting the current according to the size of the load, and some It has the function of detecting motor stall and betting rotation, and some also have the function of closed-loop position feedback..... With different core chips, the price varies greatly, but the shell is the same.

prompt: The drives we design usually only provide subdivisions of the binary law, such as **2 Subdivision (400), 4 Subdivision (800), 8 Subdivision (1600), 16 Subdivision (3200), 32 Subdivision (6400), 64 Subdivision (12800), 128 Subdivision (25600), 256(51200) Subdivision,** but does not provide **5 Subdivision (1000), 10 Subdivision (2000), 20 Subdivision (4000), 25 Subdivision (5000), 40 Subdivision (8000), 50 Subdivision (10000), 100 Subdivision (20000).** Some users may say that I originally used **25 Subdivision (5000)** then what should we do? It doesn't matter, Choose **32 Subdivision (6400)** And modify the pulse equivalent and acceleration/deceleration parameters. Choose **25 Subdivision (5000)** And selection **32 Subdivision (6400),** What is the difference? Choose **32** When subdividing, the operation will be more stable, the vibration will be smaller, the engraving precision will be better, and the cutting smoothness will be higher, but the maximum engraving speed will be slightly reduced. That is to say, **the higher the subdivision, the more stable the stepper motor will run, the smaller the vibration, the better the carving precision, and the higher the cutting smoothness.** However, it is limited by the response frequency of the motor and the maximum operating speed will be Decrease, because the higher the subdivision, to achieve the same speed as the low subdivision, a higher pulse frequency is required, and the highest response frequency of the motor is generally unchanged.

If only the highest engraving speed is pursued, and the engraving and cutting effect is not pursued, then the stepper motor should choose a lower fineness

Points. In other words, high speed and high precision are usually restricted by each other!

2016 – 11-17

Prepared by Li Huiyu

(Finish)